



HOT WATER SYSTEMS

THERMANN[™]

thermann.com.au

HOT WATER YOU CAN DEPEND ON

Precision engineered for efficiency and long life, Thermann is setting new standards for hot water systems in Australia. Packed with innovative features and proven technology, Thermann delivers the ultimate hot water experience everyday. What's more, Thermann is committed to total customer care, so you'll enjoy market-leading warranties and full after sales support for many years to come.





THERMANN

THERMANN

THERMANN™ 26
GAS CONTINUOUS FLOW

CONTENTS

Residential Range

ELECTRIC STORAGE SMALL & LARGE	5-7
GAS STORAGE	8
CONTINUOUS FLOW	9-12

E-Plus Range

CONTINUOUS FLOW C7	15-16
EVACUATED TUBE SOLAR ELECTRIC BOOSTED	17-18
EVACUATED TUBE SOLAR GAS BOOSTED	19-20
HYBRID HEAT PUMP	21-22
SPLIT HEAT PUMP	23-24

ELECTRIC STORAGE SMALL HOT WATER SYSTEM



Thermann small Electric Storage hot water units allow you to install Hot water where space and access is restrictive. With its “V fit” configuration, inlets and outlets are configured for ease of installation. Available in ‘appliance white’ for a more aesthetically pleasing unit.

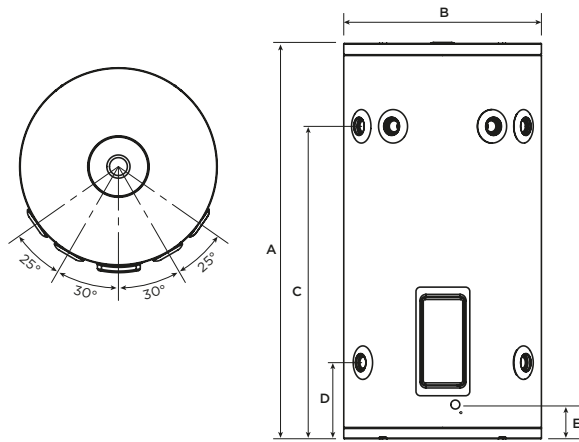

SPECIFICATIONS

Electric Tank

Measurements	25L	50L
Total Height (A)	455	670
Total Diameter (B)	405	405
Outlet Height (C)	275	490
Inlet Height (D)	145	145
Electrical Entry (E)	70	70
Element Angle (K)	55°	55°
Storage Capacity (litres)	31	50
Hot Water Delivery (litres)	25	50
Net Weight Empty (kg)	17	23
Element Size (kW)	2.4*, 3.6	2.4*, 3.6
Relief Valve		
Pressure (kPa)	1000	1000
Max Inlet Pressure		
Without an ECV (kPa)	800	800
With an ECV (kPa)	650	650

Selecting the right unit for you

	25L	50L
Inlet/Outlet	Dual Handed	Dual Handed
No. People (continuous)	1	1-2
No. People (off peak)	0	0



Cylinder



Parts and labour



*2.4kW plug in only

ELECTRIC LARGE HOT WATER SYSTEM



Thermann electric storage hot water units are an insulated storage vessel efficiently storing hot water, ready for use, when you need it. The Thermann range of electric water heaters offer solutions in eight different sizes to suit your needs.

RANGE FEATURES

- Commercial grade enamel and a thicker anode
- Easy installation, with water connections on both sides of tank
- Full flow pressure to all outlets
- Australian made
- 10-year tank warranty, including 1-year full parts and labour*

SPECIFICATIONS

Electric Tank

Measurements	80L	125L	160L	250L	315L	400L
Total Height (A)	925	1090	1315	1445	1765	1705
Total Diameter (B)	490	530	530	620	620	705
Outlet Height (C)	735	865	1095	1210	1530	1445
Inlet Height (D)	160	190	190	195	195	220
Electrical Entry (E)	85	100	100	105	105	130
Element Angle (K)	55°	55°	55°	72°	72°	72°
Storage Capacity	88	130	161	259	321	415
Hot Water Delivery	80	125	160	250	315	400
Net Weight Empty	41	51	59	72	93	115
Element Sizes (kW)	3.6	1.8, 3.6	2.4, 3.6	3.6	3.6	3.6
Relief Valve						
Pressure (kPa)	1000	1000	1000	1000	1000	1000
Max Inlet Pressure						
Without an ECV (kPa)	800	800	800	800	800	800
With an ECV (kPa)	650	650	650	650	650	650

Selecting the right unit for you

	80L	125L	160L
Inlet/Outlet	Dual Handed	Dual Handed	Dual Handed
No. People (continuous)	2-3	3-4	3-5
No. People (off peak)	0	0	1-3
	250L	315L	400L
Inlet/Outlet	Dual Handed	Dual Handed	Dual Handed
No. People (continuous)	3-5	4-6	5-9
No. People (off peak)	1-3	2-4	4-6

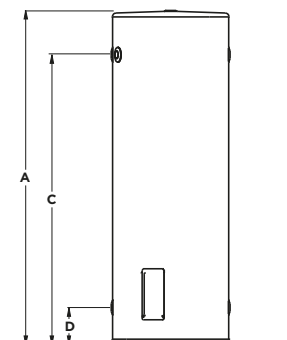
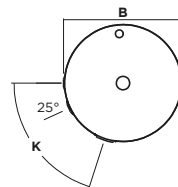



Thermann twin element electric water heaters
 Feature a secondary 'top' element, to heat an additional capacity of water to reduce the chance of running out. This is often referred to as a 'boost capacity', and can be continually heated as hot water is used.

TWIN ELEMENT FEATURES

- Cost effective - primary heating with off-peak and a continuous backup supply
- Flexible - ideal for varying hot water loads
- Limited tariffs - perfect for regions where extended off-peak tariffs are unavailable
- Space efficient - for when there's no room for a larger tank
- Fast hot water - the boost capacity can be heated (and reheated) quickly

SPECIFICATIONS

Electric Tank - Twin Element

Measurements	250L	315L	400L
Total Height (A)	1445	1765	1705
Total Diameter (B)	620	620	705
Cold Water Inlet (C)	195	195	220
Hot Water Inlet (D)	1210	1530	1445
Electricity Entry (E)	105	105	130
Storage Capacity (L)	259	321	415
Hot Water Delivery Rating (L)	250	315	400
Boost Capacity (L)	50	50	80
Net Weight Empty (kg)	72	93	115
Element Sizes (kW)	2 x 3.6kW	2 x 3.6kW 2 x 4.8kW	2 x 4.8kW
Relief Valve			
Pressure (kPa)	1000	1000	1000
Max Inlet Pressure			
Without an ECV (kPa)	800	800	800
With an ECV (kPa)	650	650	650

All Thermann residential electric storage water heaters are dual-handed for ease of installation and operate at 240V AC single phase electricity supply.



Cylinder



Parts and labour

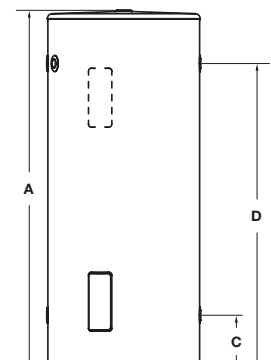
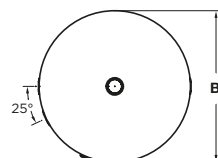

GAS STORAGE HOT WATER SYSTEM



The Thermann 4 Star Gas hot water heater can suit any family type. With an adjustable thermostat for safety and efficiency it allows you to be in control of your operating costs and performance. The unit has a small footprint which makes it ideal for replacing a 3 Star changeover.

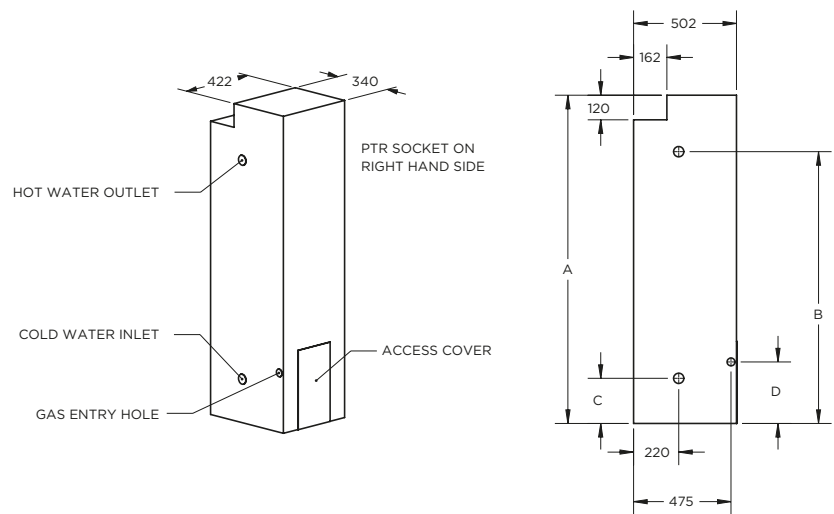

SPECIFICATIONS

Gas Tank

Measurements	135L	170L
Capacity (litres)	135	170
Net Weight Empty (kg)	72	86
Relief Valve Pressure (kPA)	1400	1400
Gas Consumption (MJ/h)	NG - 28 LPG - 26	NG - 33
Recovery rate @ 45°C rise (L/hr)	NG - 122 LPG - 115	NG - 145
First Hr Capacity	NG - 257 LPG - 250	NG - 315
Dimensions (mm)	135L	170L
Height (A)	1600	1900
Hot Water Outlet (B)	1325	1620
Cold Water Inlet (C)	220	220
Gas Inlet (D)	300	300
Water Inlet/Outlet	Left	Left

Selecting the right unit for you

	135L	170L
No. People	3-4	4-5



Cylinder



Parts and labour



Specifications correct for gas storage models manufactured after 13 January, 2020.

CONTINUOUS FLOW 6 STAR HOT WATER SYSTEMS



The ThermaNN 6 Star, energy efficient Gas Continuous Flow unit ensures you will have enough hot water, when you need it. With a 12 year warranty, you can rest assured you are covered for the life of the unit, and universal controllers ensure you always have precise control of your hot water temperature settings.

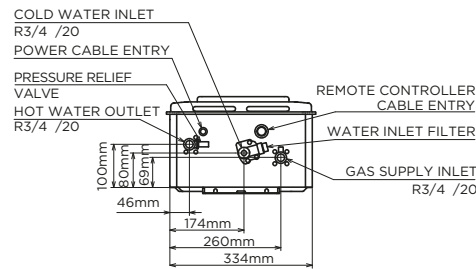
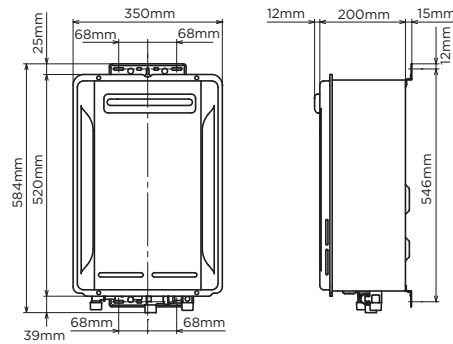

Recess Box Painted (optional)



Universal Controller (optional)

SPECIFICATIONS

Continuous Flow 6 Star

Measurements	16L	20L	26L
Nominal hourly gas consumption (MJ/h)	125	158	200
Test point pressure (NG) (kPa)	0.56	0.8	0.8
Test point pressure (LPG) (kPa)	0.91	1.4	1.5
Minimum water pressure (kPa)	60	90	110
Maximum water pressure (kPa)	1200	1200	1200
Minimum gas inlet pressure NG (kPa)	1.13	1.13	1.13
Minimum gas inlet pressure LPG (kPa)	2.75	2.75	2.75
Maximum gas inlet pressure NG (kPa)	5.0	5.0	5.0
Maximum gas inlet pressure LPG (kPa)	7.0	7.0	7.0
Minimum Flow Rate Ignition (L/min)	2.7	2.7	2.7
Input voltage single phase 50Hz (V)	240	240	240
Maximum output current (A)	0.39	0.45	0.46
Inlet gas connection male thread	R3/4" (20mm)	R3/4" (20mm)	R3/4" (20mm)
Cold water connection male thread	R3/4" (20mm)	R3/4" (20mm)	R3/4" (20mm)
Hot water connection male thread	R3/4" (20mm)	R3/4" (20mm)	R3/4" (20mm)
Relief valve pressure setting (kPa)	1400	1400	1400
Weight dry (kg)	15	15	16
Dimensions (HxWxD mm)	520x350x200	520x350x200	520x350x200

Optional Accessories	Code
Universal controller with 15m cable	9505082
6* Recess Box Painted	9505219
6* Recess Box Gal	9505218
6* Locking Bracket	9504679
6* Flue Diverter	9505161

Selecting the right unit for you

	16L	20L	26L
No. Outlets	1	1-2	2-3
Energy Rating (Stars) (50°C)	6.3	6.5	6.1
Energy Rating (Stars) (60°C)	6.0	6.0	6.0
Capacity @ 25° rise (L/min)	16L	20L	26L
Capacity @ 40° rise (L/min)	10	12.5	16.25
Gas Type Available	NG, LPG	NG, LPG	NG, LPG



Heat Exchanger

Parts and labour

IAPMO Approval certificate no. GMK10409. Watermark Certificate of compliance WM-000506

CONTINUOUS FLOW R-SERIES

HOT WATER SYSTEMS



The R-Series range now includes the 17R, 21R, and 26R 50°C models in addition to the existing large capacity 32R model in 50°C and 60°C options. The range provides sizing options for applications big, small, and everything in between.

The 26R model claims the title as the most efficient in its class*. It not only features an equivalent energy efficiency rating of 6.4 stars, but its low minimum flow rate makes it the perfect choice to combine with water efficient 6-star tapware.

Selecting the right unit for you

	17L	21L	26L	32L
No. Outlets	2	2 - 3	3	4
Energy Rating (Stars)	6.0	6.1	6.4	5.8
Capacity @ 25° rise (L/min)	17	21	26	32
Capacity @ 40° rise (L/min)	11	13	16	20
Gas Type Available	NG, LPG	NG, LPG	NG, LPG	NG, LPG



Heat Exchanger



Parts and labour

SPECIFICATIONS

Continuous Flow 17R, 21R, 26R, 32R

Measurements	17L	21L	26L	32L
Nominal hourly gas consumption (MJ/h)	126 (NG) 127 (LPG)	159	195	250
Test point pressure NG (kPa)	0.61	0.62	0.69	0.25 (Min) 0.70 (Max)
Test point pressure LPG (kPa)	0.71	0.77	0.87	0.49 (Min) 1.51 (Max)
Minimum water pressure (kPa)	200	200	200	200
Maximum water pressure (kPa)	1000	1000	1000	1000
Minimum gas inlet pressure NG (kPa)	1.13	1.13	1.13	1.13
Minimum gas inlet pressure LPG (kPa)	2.75	2.75	2.75	2.75
Maximum gas inlet pressure NG (kPa)	3.0	3.0	3.0	3.0
Maximum gas inlet pressure LPG (kPa)	3.5	3.5	3.5	3.5
Minimum flow rate ignition (L/min)	2.5	2.5	1.5	2.0
Input voltage single phase 50HZ (v)	230 - 240	230 - 240	230 - 240	230 - 240
Maximum output current (A)	0.44	0.44	0.54	0.6
Inlet gas connection male thread	R3/4" (20mm)	R3/4" (20mm)	R3/4" (20mm)	R3/4" (20mm)
Cold and hot water connections male thread	R3/4" (20mm)	R3/4" (20mm)	R3/4" (20mm)	R3/4" (20mm)
Relief valve pressure setting (kPa)	1620	1620	1620	1620
Weight dry (kg)	14	15	16	30
Dimensions (HxWxD mm)	520x350x170	520x350x170	520x350x170	615x464x240

*The Thermann 26R has the lowest annual energy consumption of any non-condensing 26L/min continuous flow model in the Australian market
IAPMO Approval certificate no. GMK-10614. Watermark Certificate of compliance WMKA20083

17R,21R

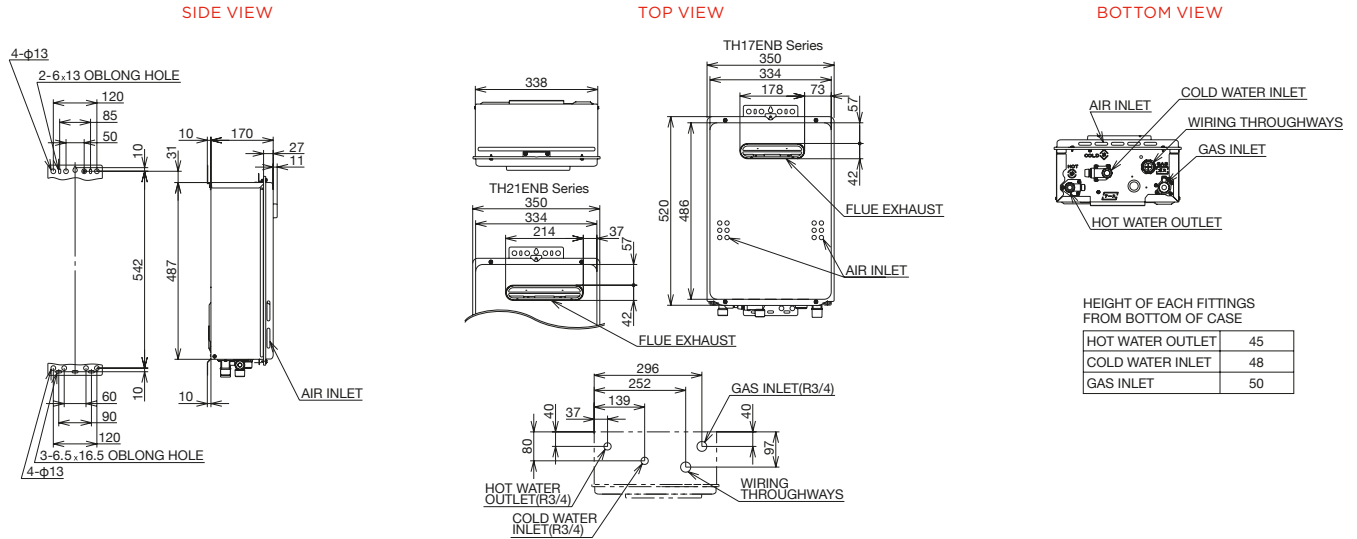

26R

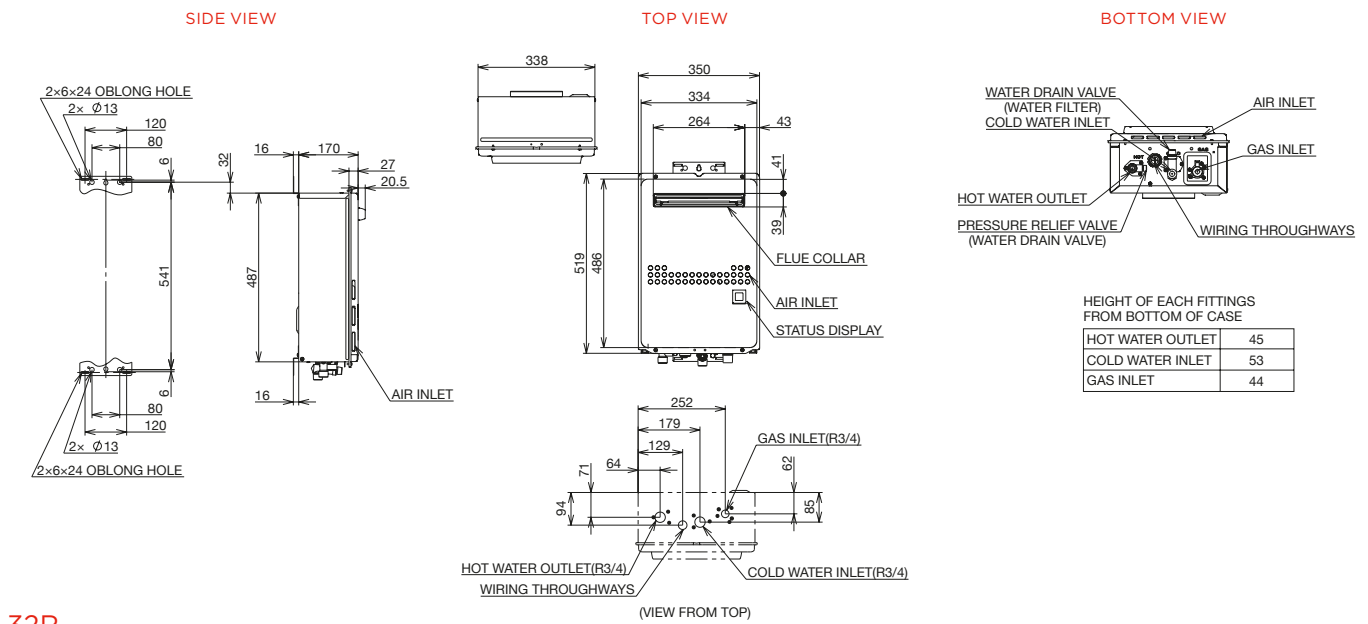

32R

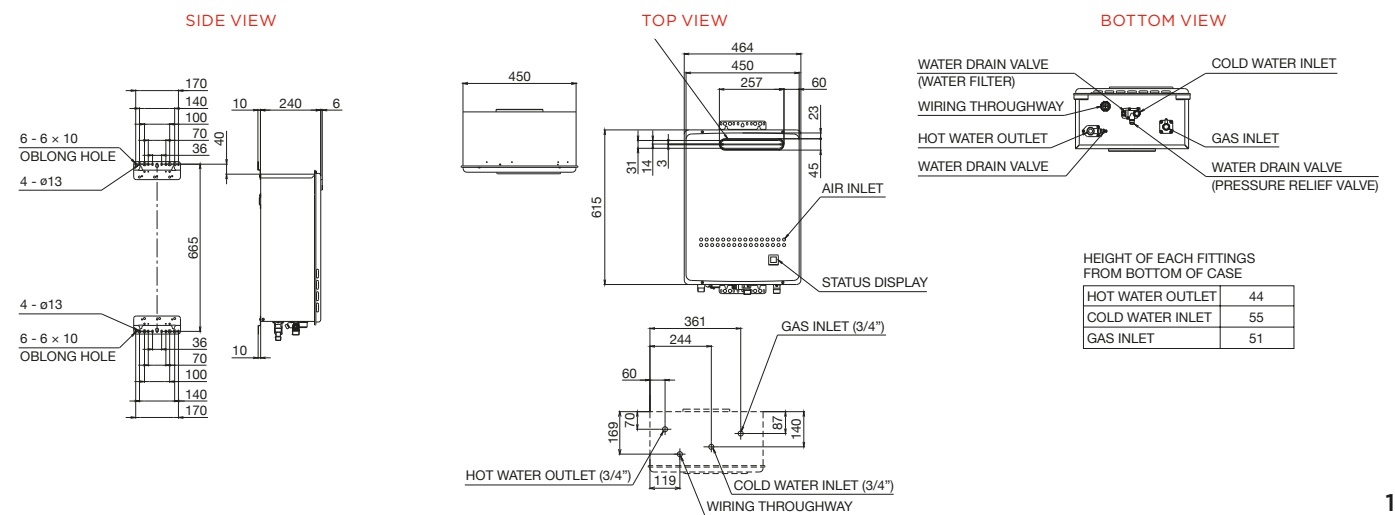

CONTINUOUS FLOW R-SERIES

HOT WATER SYSTEMS

The R-Series has a full range of optional accessories available, including remote temperature controllers for precise temperature control, recess wall boxes for discreet installation in wall cavities, flue diverters for compliance and anti-theft brackets for added security.

Main Controller



Bathroom Controller 1



Bathroom Controller 2



Optional Accessories	Code
Controllers	
R-Series Main Controller	9507958
R-Series Bathroom 1 Controller	9507959
R-Series Bathroom 2 Controller	9507960
Commercial Controller - Suits 32L only (Internal controller)	9507385
Quick Connect cable (2m) - Suits 32L only (Must be used with Commercial controller when linking up to 2 units together)	1309044
Recess Boxes	
32R Half Recess Box	1309048
17R 21R 26R Half Recess Box	2571022
17R 21R 26R Full Recess Box	2571023
Pipe Covers	
17R 21R 26R Pipe Cover	2571026
32R Pipe Cover	1309045
Flue Diverters	
17R Side Flue Diverter	2571027
21R Side Flue Diverter	2571028
26R Side Flue Diverter	2571029
26R Side Flue Diverter - Long	2571030
32R Side Flue Diverter	1309047
32R Upward Flue Diverter	1309046

Note: All 32R controllers come with a standard 10m cable

*Both the Quick Connect Cable & Commercial Controller are required when connecting two units together.

Only a Commercial Remote is required when connecting a unit to a circulating pump e.g. for applications with a ring main.



THERMANN™

YOUR HOT WATER SHOULDN'T COST THE EARTH

More and more households are looking at ways to reduce their energy bills as well as reducing their carbon footprint.

The E-plus symbol highlights Thermann hot water units that reduce emissions and lower your running costs.



Good for the planet

Powered by the world's most energy efficient technologies, Thermann's E-plus units will greatly reduce your carbon footprint.



Great for your wallet

Invest in your future and save on your bills. With E-plus, you'll be thousands of dollars better off over the life of the hot water unit.

CONTINUOUS FLOW C7

HOT WATER SYSTEM



The Thermann C7 high efficiency Gas Continuous Flow unit ensures you will have enough hot water, when you need it. This unit has been developed to reduce wasted energy by pre-heating the water using heat from the gas exhaust, meaning you'll use less energy. With a 12 year warranty, you can rest assured you are covered for the life of the unit, and optional universal controllers ensure you always have precise control of your hot water temperature settings. The unit is available as a 26L model in both NG and LPG to suit your gas type.

- 15% more efficient*
- Japanese technology and manufacture
- AGA approved
- Over 50 years of manufacturing experience
- Product quality guarantee
- Watermark approved
- Optional universal controllers available

SPECIFICATIONS

Continuous Flow C7

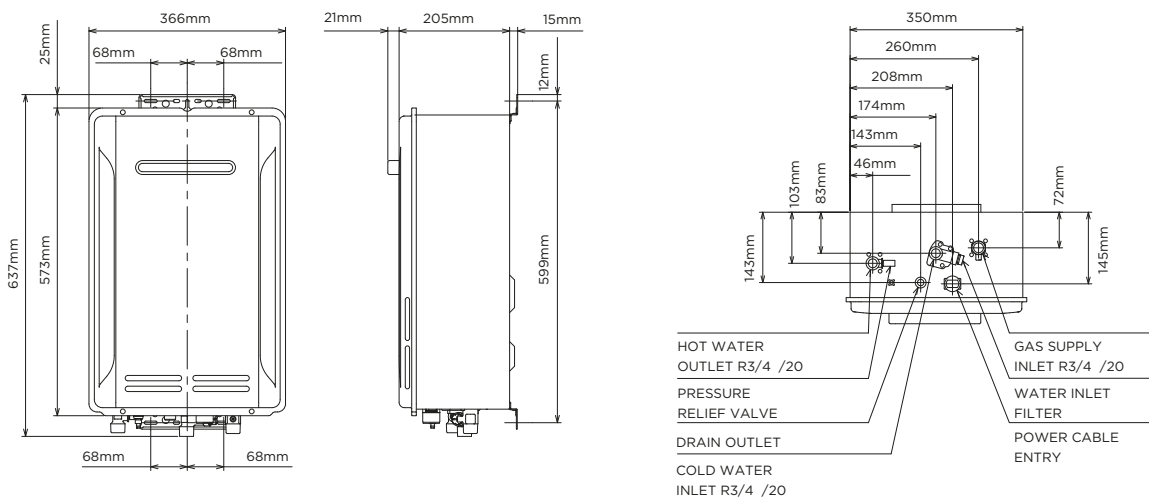

Compared to the Thermann 6 50°C model

CONTINUOUS FLOW C7

HOW IT WORKS



SPECIFICATIONS

Continuous Flow C7

Features	26L
Nominal hourly gas consumption (MJ/h)	173
Test point pressure NG (kPa)	0.84
Test point pressure LPG (kPa)	1.27
Minimum water pressure (kPa)	115
Maximum water pressure (kPa)	1200
Minimum gas inlet pressure NG (kPa)	1.13
Minimum gas inlet pressure LPG (kPa)	2.75
Maximum gas inlet pressure NG (kPa)	5.0
Maximum gas inlet pressure LPG (kPa)	7.0
Minimum flow rate ignition (L/min)	2.7
Input voltage single phase 50HZ (v)	240
Maximum output current (A) - inc. anti-frost heater	
Inlet gas connection male thread	R3/4" (20mm)
Cold water connection male thread	R3/4" (20mm)
Hot water connection male thread	R3/4" (20mm)
Condensate connection male thread	R1/2" (15mm)
Relief valve pressure setting (kPa)	1400
Weight dry (kg)	20.5
Dimensions (DxWxH mm)	205x366x573

Selecting the right unit for you

	26L	Optional Accessories	Code
No. Outlets	2-3	Universal controller with 15m cable	9505082
Energy Rating 50°C (stars)	7.3	6" Recess Box Painted	9505219
Energy Rating 60°C (stars)	7.0	6" Recess Box Gal	9505218
Capacity at 25°C rise (L/min)	26	6" Locking Bracket	9504679
Capacity at 40°C rise (L/min)	16.25	6" Flue Diverter	9505161
Gas Type Available	NG, LPG		



Heat Exchanger

IAPMO Approval Certificate no. GMK10409.
Watermark Certificate of Compliance WMKA-000506



Universal Controller (optional)

HOW IT WORKS

DEVELOPED TO REDUCE WASTED ENERGY, THIS UNIT PRE-HEATS THE WATER USING HEAT FROM THE GAS EXHAUST, MEANING YOU'LL USE LESS ENERGY.

THE PROCESS

1. A hot water tap is turned on
2. Water enters the heater
3. The water flow sensor detects the water flow
4. The computer automatically ignites the burner
5. Water circulates through the heat exchanger
6. The heat exchanger heats the water to the designated temperature
7. When the tap is turned off, the unit shuts down

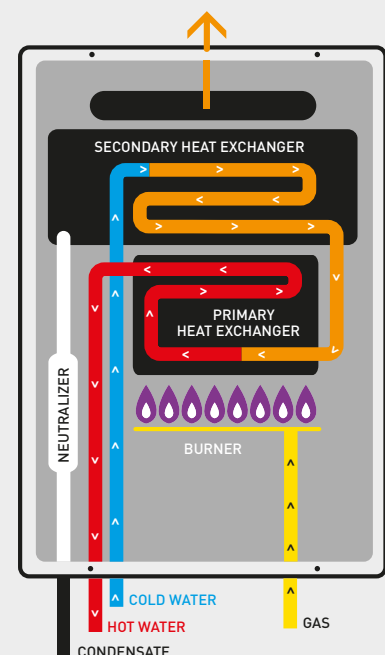

*Thermann model 26NG50C when compared to 26NG50, based on comparative energy consumption when tested to AS 4552.

**AS 4552 limits the rating shown on the energy label to 6.0 Stars. Where the calculated rating exceeds 6.0 Stars it is designated as an "equivalent" rating.

EVACUATED TUBE SOLAR ELECTRIC BOOSTED



Thermann Evacuated Tube Solar electric boosted systems harness the sun's energy to heat your water. An electric element in the tank provides back up if needed, ensuring peace of mind, whilst also reducing your running costs and environmental footprint.

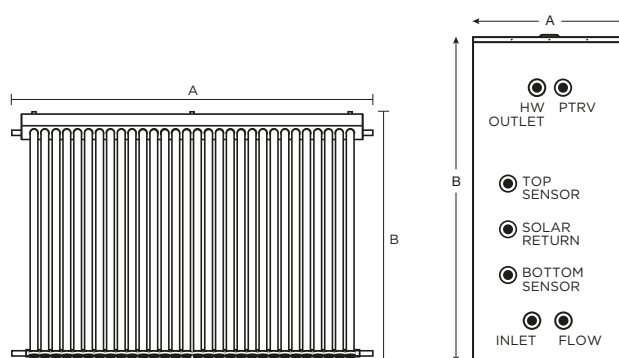

SPECIFICATIONS

Electric Boosted Tank

Measurements (mm)	250L BOT	315L BOT	315L MID	400L BOT	400L MID
Tank Diameter (A)	617	617	617	705	705
Tank Height (B)	1445	1765	1765	1704	1704
HW Outlet	1211	1531	1531	1445	1445
PTRV Port	1211	1531	1531	1445	1445
Top Sensor Port	786	872	872	809	832
Solar Return Port	567	566	504	536	554
Bottom Sensor	347	355	326	340	357
Solar Flow	197	197	197	219	219
Cold Water Inlet	197	197	197	219	219
Dry Weight (kg)	71	92	92	116	116

Roof Collector

Measurements (mm)			Dry Weight	
Collector	Width (A)	Length (B)	WO/Tubes	W/Tubes
22 Tubes	1636	2005	20kg	80.7kg
30 Tubes	2196	2005	24kg	105.7kg

Dry weights based on 2 track flush mount frame.

Selecting the right unit for you

	250L	315L	400L
No. People	3-5	4-6	5-9
No. Tubes	20	30	4v

*Other kit configurations available



Tubes



Tank



Parts and Labour



Tank

EVACUATED TUBE SOLAR

HOW IT WORKS



ELECTRIC SETUP

Electric Booster

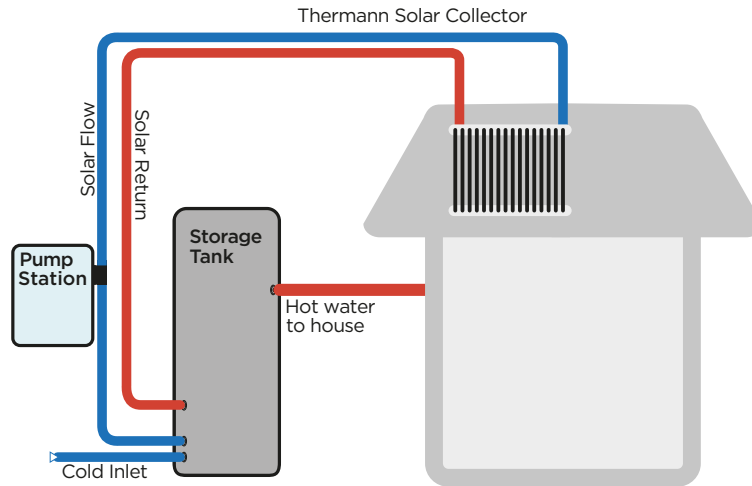

Note: Diagram not to scale - basic system overview (not installation guide).

STEP 1

The sunlight strikes the dark absorber coating inside the tube.

STEP 2

The heat pipe transfers the heat up to the copper header pipe location in the insulated manifold box.

STEP 3

A circulator moves water from the storage tank to the copper pipe warming the water. The solar heated water is then pushed down into the storage tank for use. Anti-frost is built in to the Thermann system to ensure solar hot water can be provided even in cold regions.

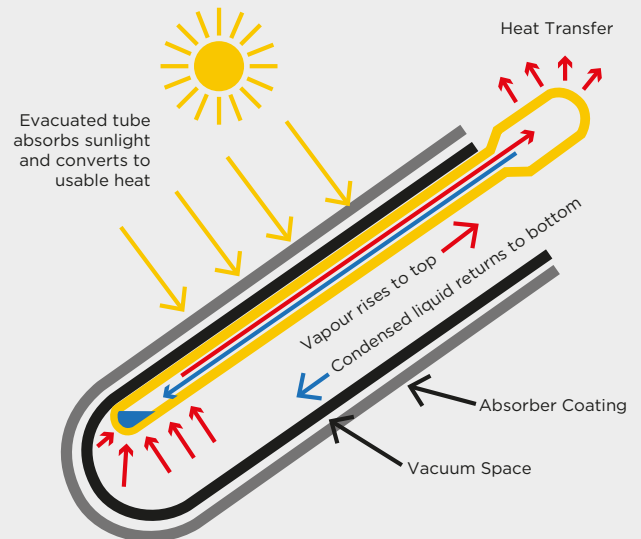

PASSIVE SUN TRACKING

The round tube design of the system passively tracks the sun throughout the day giving the highest possible performance from early morning through to late afternoon.

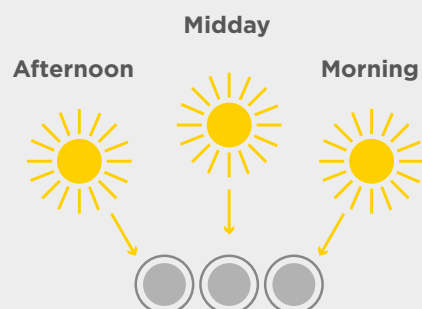

EVACUATED TUBE SOLAR GAS BOOSTED



Thermann Evacuated Tube Solar gas boosted systems offer reliability and efficiency. Passive sun tracking means more of the sun's rays are converted to usable hot water throughout the day - reducing your power bills. With the gas boosted continuous flow unit, you'll never run out of hot water, no matter the weather.

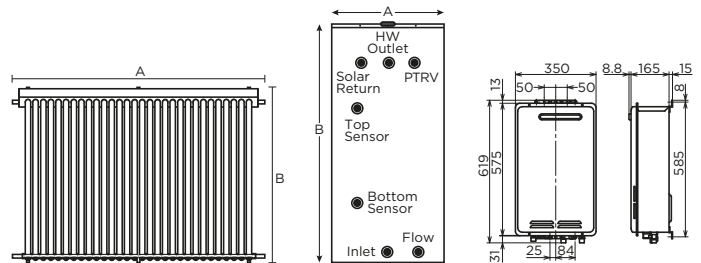

SPECIFICATIONS

Gas Boosted Tank

Measurements (mm)	250L GAS	315L GAS	400L GAS
Tank Diameter (A)	623	624	712
Tank Height (B)	1444	1762	1703
HW Outlet	1217	1535	1452
PTRV Port	1217	1535	1452
Top Sensor Port	997	1263	1215
Solar Return Port	1217	1535	1452
Bottom Sensor	463	555	561
Solar Flow	201	201	226
Cold Water Inlet	201	201	226
Dry Weight (kg)	71	92	116

For 26L Gas Continuous Flow specifications and warranty information refer to page 6.

Roof Collector

Measurements (mm)			Dry Weight	
Collector	Width (A)	Length (B)	WO/Tubes	W/Tubes
22 Tubes	1636	2005	20kg	80.7kg
30 Tubes	2196	2005	24kg	105.7kg

Dry weights based on 2 track flush mount frame.

Selecting the right unit for you

	160L	250L	315L	400L
No. People	1-2	3-5	4-6	5-9
No. Tubes	22	22	30	44
Gas Booster	26L	26L	26L	26L



Tubes



Tank



Parts and Labour



Tank



Continuous Flow Unit

EVACUATED TUBE SOLAR

HOW IT WORKS



GAS SETUP

Gas Booster

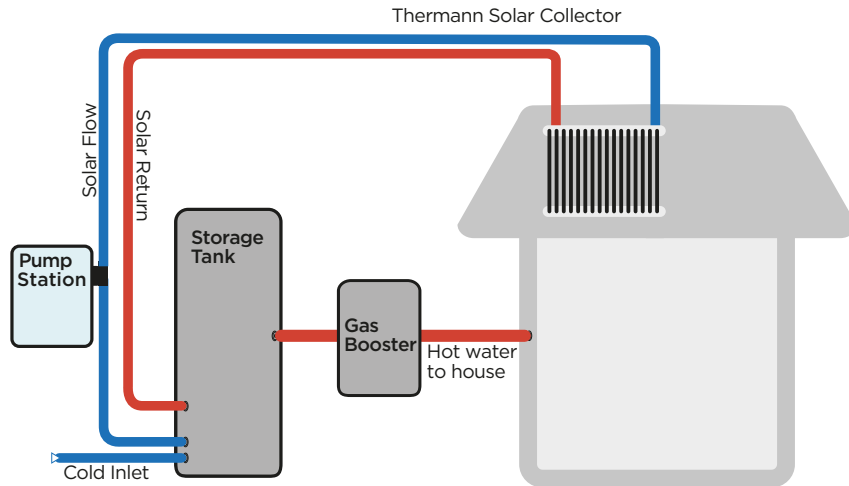

Note: Diagram not to scale - basic system overview (not installation guide).

STEP 1

The sunlight strikes the dark absorber coating inside the tube.

STEP 2

The heat pipe transfers the heat up to the copper header pipe location in the insulated manifold box.

STEP 3

A circulator moves water from the storage tank to the copper pipe warming the water. The solar heated water is then pushed down into the storage tank for use. Anti-frost is built in to the Thermann system to ensure solar hot water can be provided even in cold regions.

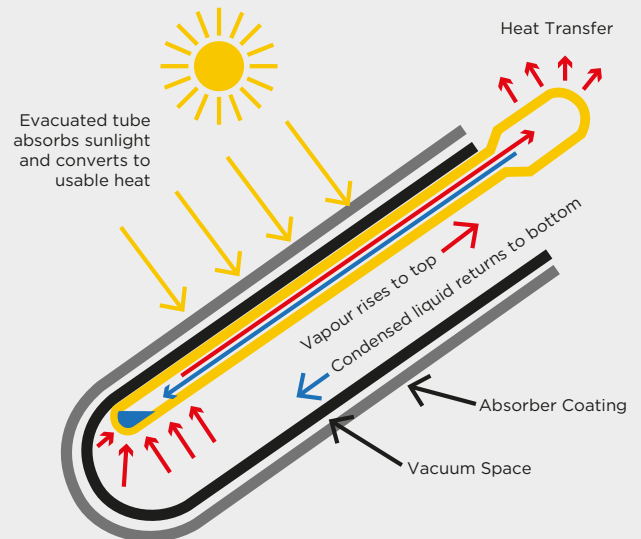

PASSIVE SUN TRACKING

The round tube design of the system passively tracks the sun throughout the day giving the highest possible performance from early morning through to late afternoon.

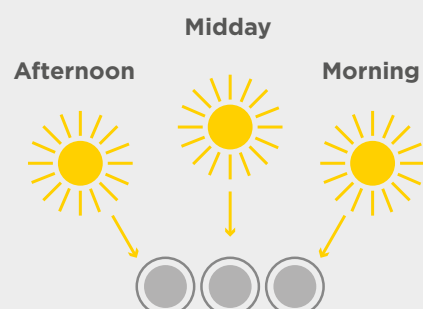

HYBRID HEAT PUMP

HOT WATER SYSTEM



Engineered in Germany for Australian conditions, the **Thermann X Hybrid Heat Pump** extracts heat from ambient air and quietly transfers it to heat water. It comes with a removable casing for easy cleaning and servicing where access is limited. With a built in manual element boost, for high demand conditions, and Solar PV ready it truly is the smart way to heat your water.

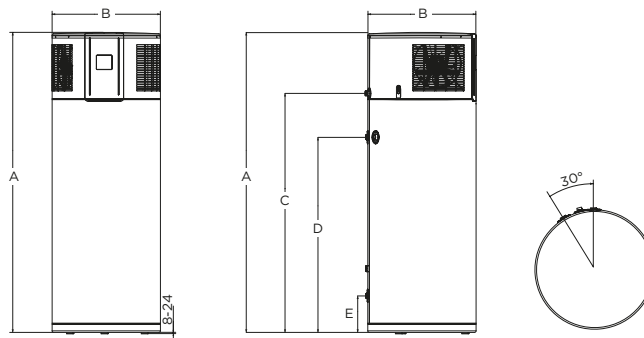

SPECIFICATIONS

Thermann Hybrid

Electrical details	220L	300L
Rated Voltage	230	230
Rated Current (Amps)	9.70	9.70
Power Consumption Boost Element (kW)	1.6	1.6
Specifications		
Application Range (Operating Temp.)	-5 to +42°C	-5 to +42°C
Seasonal Coefficient of Performance (COP)	3.94	3.58
PTR Valve (kPa)	850	850
Refrigerant	R134a	R134a
Refrigerant Capacity (kg)	0.85	0.85
Anode Type	Maintenance-Free Impressed Current Anode	Maintenance-Free Impressed Current Anode
Measurements		
Cylinder Capacity (L)	220	300
Total Height (A)	1545	1913
Total Diameter (B)	690	690
Electrical Entry (C)	1160	1150
Outlet Height (D)	935	1287
Inlet Height (E)	218	218
Weight (Empty)	120	135



Cylinder



Parts and labour



HYBRID HEAT PUMP

HOT WATER SYSTEM



HOW IT WORKS

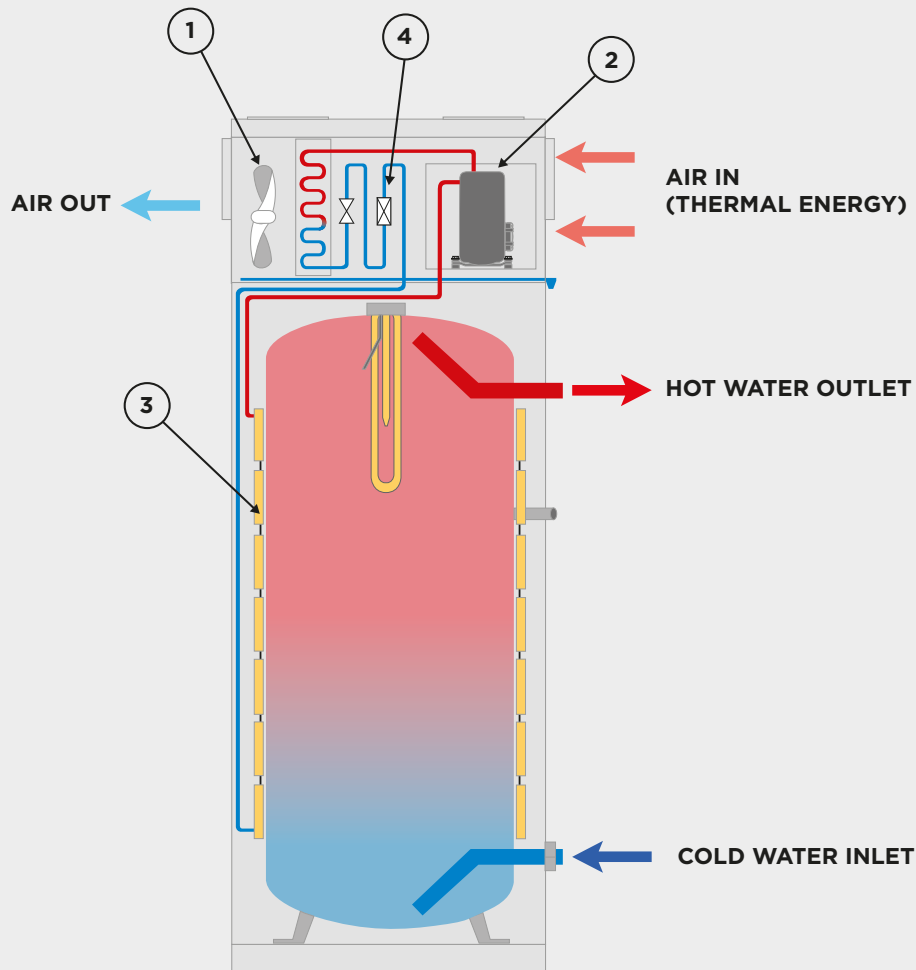

1. A fan draws air through an evaporator. Thermal energy within the air is transferred to a liquid refrigerant causing it to change into a gas.
2. The refrigerant gas is then drawn into a compressor which increases the pressure and as a result increases the temperature.
3. A condenser (heat exchanger) then transports the hot gas refrigerant around the outside of the water tank. This heats the water inside the tank and the gaseous refrigerant reverts into a liquid.
4. The pressure of the refrigerant is reduced as it goes through an expansion valve and returns to the evaporator for the process to start again.

SPLIT HEAT PUMP HOT WATER SYSTEM



Combining Japanese and Australian engineering, The **Thermann X Split Heat pump** is a flexible, quiet, and highly efficient hot water solution for any climate. By extracting heat from the air, this clever system uses a naturally occurring gas to heat water making it up to 80% more efficient than that of a standard electric storage system.

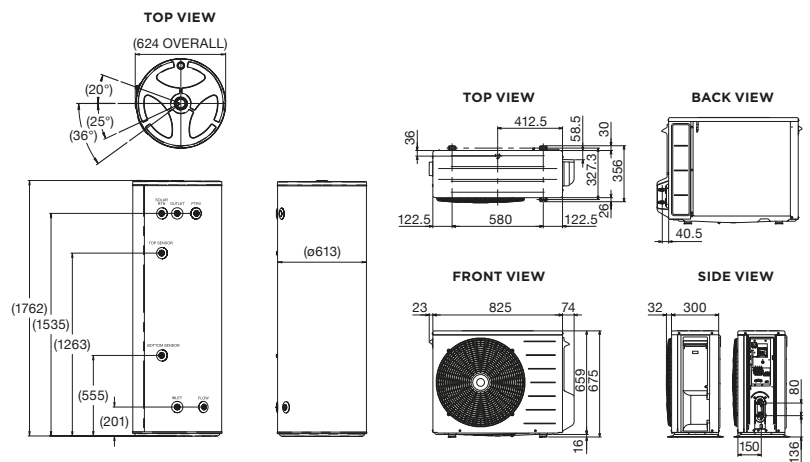

SPECIFICATIONS

Heat pump unit

Measurements	
Refrigerant type	R744 (CO2)
Seasonal Coefficient of Performance	5.08
Setting outlet water temp	65 °c
Product weight	48 kg
Rated capacity	4.5 kW
Max. power Input	2.5kW
Max. current	11A
Max. voltage	240v
Design pressure (High/Low)	14/9 MPa
Protection raining Class	IPX4
MAX operating water pressure	850 kPa
Operating Range	-10 to +43
Operating Noise	37dB
Rated power consumption	0.95kW/h

Tank

Measurements	
Measurement	Detail
Total volume	323L
Tank unit	92kg
PTRV pressure rating	850kPa
Sensor level on tank	69%
Dimensions	
Diameter	613mm
Height	1763mm
Hot water outlet	
PTR valve	1535mm
Heat Pump return	
Sensor	555mm
Cold water inlet	
Heat pump flow	201mm



Heat pump unit



Cylinder



Parts and labour



Heat pump unit



Cylinder

Selecting the right unit for you

	315L x 4.5kW
No. People	2-6

SPLIT HEAT PUMP

HOW IT WORKS



HOW IT WORKS

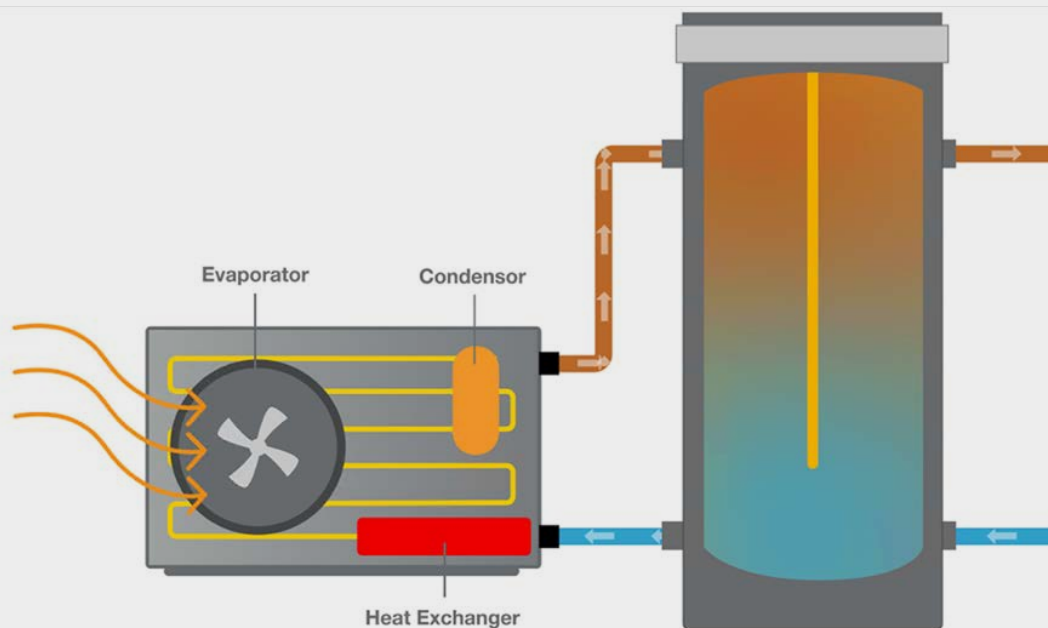

1. Water from the main fills the storage tank with cold water.
2. Water is drawn from the tank into the heat pump unit
3. A fan forces air through an evaporator where the heat from the air is transferred to a natural refrigerant gas.
4. The heated gas is then circulated around a compressor to be pressurised. This pressurisation causes the temperature of the gas to significantly rise.
5. The hot gas passes through a heat exchanger to heat the cold water, which is then pumped back into the top of the storage tank ready to use.

thermann.com.au

Reece. Works for you.™

Call **1800 032 566** or visit www.reece.com.au for your nearest Reece store.

Due to limitations in the printing process the colours in this brochure are a guide only.

The manufacturer/distributor reserves the right to vary specifications or delete models from their range without prior notification. The manufacturer/distributor takes no responsibility for printing errors.

All products enjoy a product replacement warranty. For full warranty details visit www.reece.com.au/productquality

V17 [BROCHURE CODE 2130530]

THERMANN™

reece™